

# K50APT2WXDQ

## Pick-to-Light – Placement Sensor

### Capacitive Sensor

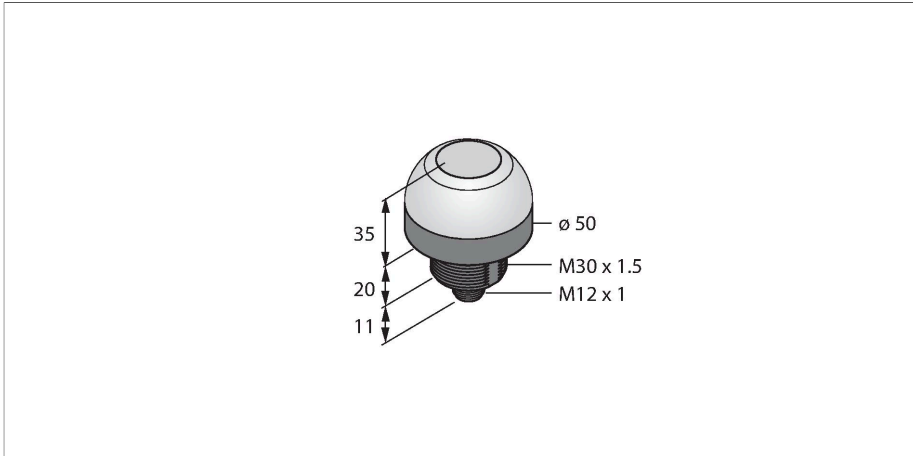

#### Technical data

Type	K50APT2WXDQ
ID	3800425
<b>Signal and display data</b>	
Purpose	Pick-to-Light
Function	Touch Button
Switch Function	Momentary
Features of color 1	White, Permanently on
Special features	I/O module-compatible Wash down
<b>Electrical data</b>	
Operating voltage	12...30 VDC
DC rated operational current	≤ 150 mA
Max. current consumption per color	75 mA
Output function	NO contact, PNP
Input type	PNP
Response time typical	< 50 ms
<b>Mechanical data</b>	
Design	Dome, K50
Dimensions	Ø 50 x 66 mm
Housing material	Plastic, PC, Black
Window material	Polycarbonate, diffuse
Electrical connection	Connector, M12 × 1, PVC
Number of cores	5
Ambient temperature	-40...+50 °C
Relative humidity	0...90 %
Protection class	IP67

#### Features

- Protection class IP67/IP69K
- M12 × 1 connector
- Job light: white
- Mispick: -
- Trigger light: -
- Operating voltage 12...30 VDC
- PNP switching
- NO contact
- Capacitive sensor of the second generation
- High immunity to false actuation by splashing, detergents, oils and other contaminants

#### Wiring diagram

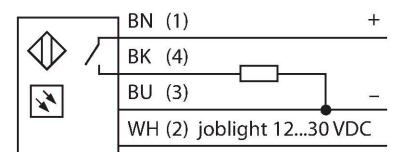

#### Functional principle

The K50 pick-and-place sensor is suitable for many mounting and component placement applications. The green work light or other signal lights are reflected perfectly by the entire dome (depending on the version). The transistor output can be easily connected to a system control, which is programmed for a special task sequence. The work light of the sensor is located in or next to every bin at the operator's workstation and indicates: 1. The bins with the components to be picked up for a particular work step and 2. the sequence in which the components have to be picked up. If the operator removes a part from the bin, the K50 detects the hand in the bin and sends a signal to the control unit. The system then checks if the

## Technical data

IP69

Tests/approvals	
MTTF	146 years acc. to SN 29500 (Ed. 99) 40 °C
Approvals	
	CE, cULus listed

correct component has been picked up and – depending on the configuration – switches the corresponding work light off and the next one on, according to the assembly sequence. The work sequence control leads to increased efficiency, improved quality control and reduces rework and testing expenses. The term work light therefore refers to the visual indicator of the bin from which a part should be removed next. The actuation indicator confirms the removal with a different color. The misspick indicator illuminates if a bin was reached into when the work light was not set.

## Accessories

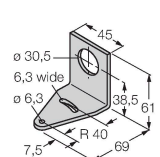
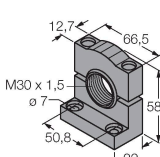
SMB30A	3032723	SMB30SC	3052521
 <p>Mounting bracket, rectangular, stainless steel, for sensors with 30mm thread</p>		 <p>Mounting bracket, PBT black, for sensors with 30 mm thread, rotatable</p>	

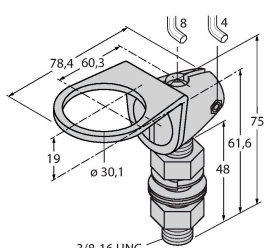
SMB30FA	3074005
 <p>Montagewinkel; Werkstoff VA 1.4401</p>	

## Accessories

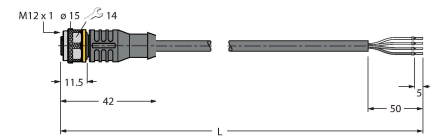
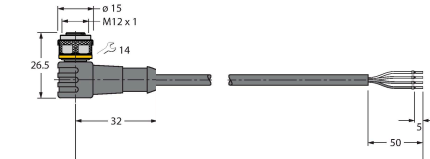
Dimension drawing	Type	ID	
	RKC4.4T-2/TEL	6625013	Connection cable, M12 female connector, straight, 4-pin, cable length: 2 m, jacket material: PVC, black; cULus approval
	WKC4.4T-2/TEL	6625025	Connection cable, M12 female connector, angled, 4-pin, cable length: 2 m, jacket material: PVC, black; cULus approval